



# MAX-FIRE ELECTRONIC ADVANCE DISTRIBUTORS

## The first all electronic distributor with a built-in CD ignition!

- Combines all of the features of a modern digital capacitive discharge ignition with a state-of-the-art electronic advance distributor
- Multi-Strike CD features:
  - Digital processing for maximum timing accuracy
  - The latest hi tech surface mount technology
  - Fires multiple sparks for 20+ degrees at low engine speeds for better throttle response, quicker acceleration and cleaner burning plugs
- Full electronic timing control - both RPM and vacuum based
  - There are 7 preprogrammed custom advance curves or design your own using free windows based software
  - The Vacuum Advance comes preprogrammed for high performance use or it can be custom curved using the design software included
  - The 3 BAR Map Sensor allows for fully adjustable boost proportional retard and can handle up to 30 pounds of boost
- Single stage rev limiting, easy to adjust either inside the distributor or with the software - no chips required
- The free windows-based software runs on any laptop or PC, whether the distributor is in the engine or not.
- All Wiring Harnesses are included and feature weather proof terminals for maximum dependability
- All CNC-machined billet construction to ensure maximum precision
- Interchangeable Distributor Cap feature allows for 2 popular cap styles to be used to best suit the application and available clearance
- Available immediately for Chevrolet and Ford V8 engines with more applications coming soon - just ask us!



#1248204

PART NUMBER	DESCRIPTION
1248214	Chevrolet V8 262-400, 396-502 with Small Cap
1248204	Chevrolet V8 262-400, 396-502 with COMP 9000 Cap
1255104	Ford V8 260-302W with COMP 9000 Cap
1255404	Ford V8 351W with COMP 9000 Cap
1256704	Ford V8 351C-460 with COMP 9000 Cap



# E-FIRE ELECTRONIC ADVANCE DISTRIBUTORS

## A true "Fire Up and Go" all-electronic advance distributor!

- Unlike some competitors, Mallory's E-Fire Distributor Series do not require an external ignition box
- Full electronic timing control - both RPM and vacuum based
  - There are 7 preprogrammed custom advance curves or design your own using free windows-based software
  - The vacuum advance comes preprogrammed for high performance use or it can be custom curved using the design software included
  - The 3 BAR Map Sensor allows for fully adjustable boost proportional retard and can handle up to 30 pounds of boost
- Single stage rev limiting, easy to adjust using the included software - no chips required
- The free windows-based software runs on any laptop or PC, whether the distributor is in the engine or not
- All Wiring Harnesses are Included and feature weatherproof terminals for maximum dependability
- All CNC-machined billet construction to ensure maximum precision
- Interchangeable Distributor Cap feature allows for 2 popular cap styles to be used to best suit the application and available clearance
- Available immediately for Chevrolet and Ford V8 engines, with more applications coming soon - just ask us!

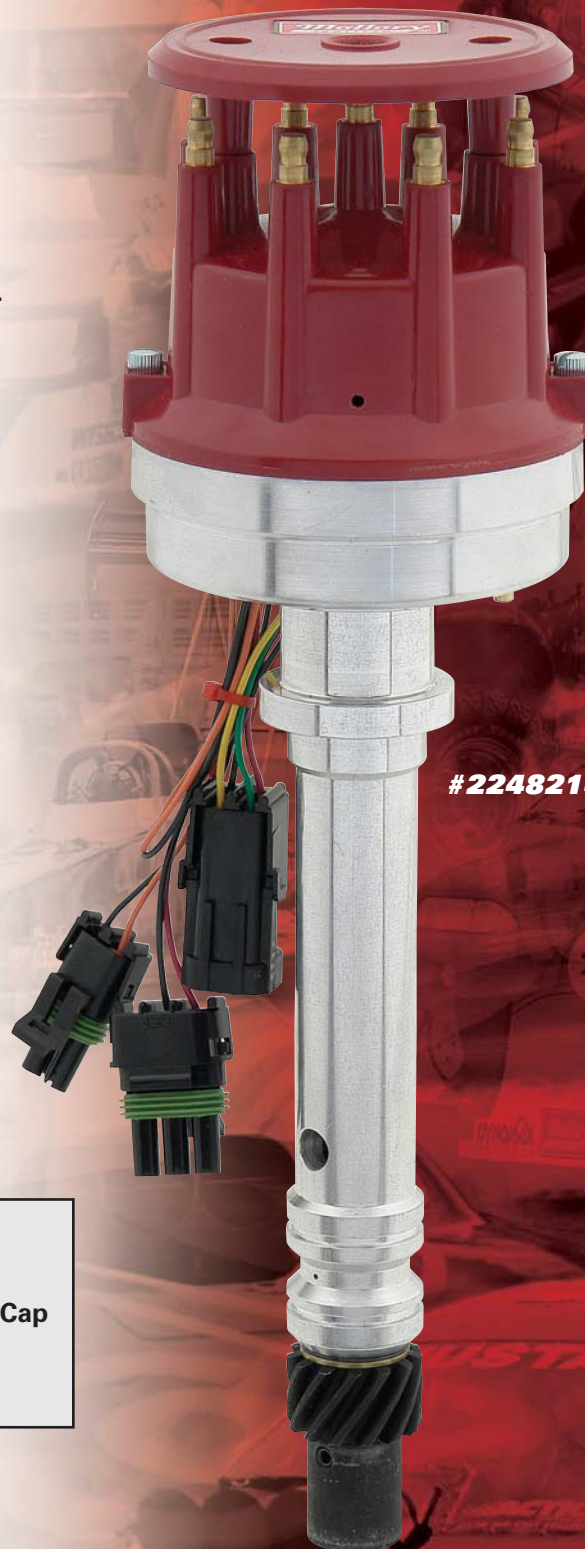

#2248214

PART NUMBER	DESCRIPTION
2248214	Chevrolet V8 262-400, 396-502 with Small Cap
2248204	Chevrolet V8 262-400, 396-502 with COMP 9000 Cap
2255104	Ford V8 260-302W with COMP 9000 Cap
2255404	Ford V8 351W with COMP 9000 Cap
2256704	Ford V8 351C-460 with COMP 9000 Cap



Mallory is a division of Prestolite Performance  
Cleveland, Ohio

©2007

[www.malloryracing.com](http://www.malloryracing.com)

74343G

